

## DELTA SYSTEM MS 500 / MS MEMBRANES WALL BUILD UP OPTIONS

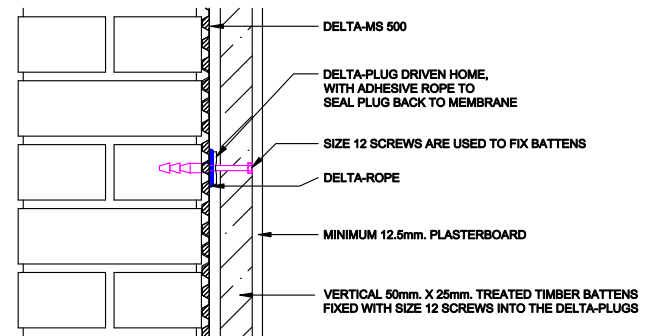
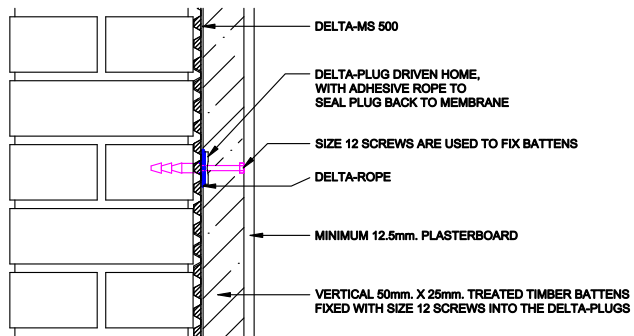
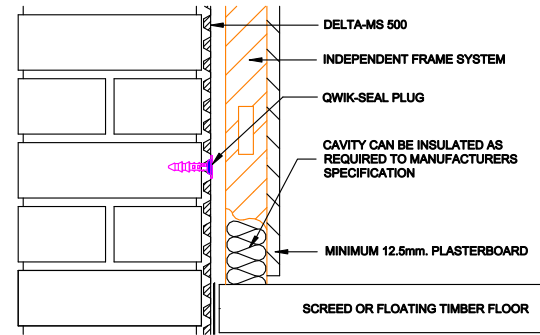
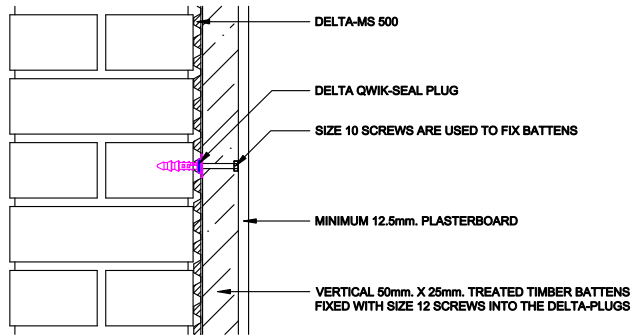

### TYPE C, DRAINED PROTECTION, WALL AND FLOOR APPLICATION

# DELTA

## MEMBRANE SYSTEMS LTD.

DRAWING No: DW-123-1- (F)

DRAWING TITLE: WALL BUILD UP OPTIONS TO MS500

DELTA HOUSE, MERLIN WAY, NORTH WEALD, EPPING, ESSEX CM16 6HR  
TEL: 01992 523523 FAX: 01992 523250

OFFICE USE:

REVISION No:

1

REVISION DATE:

June 2017

Drawn By:

Checked By:

Scale:

System Files: PDF / DWG

DRAWING NOTE:

This drawing is for illustrative purposes only. Drawing not to scale.

PROJECT / COMMENTS:

DRAWING NOTES:

All installations to be carried out in strict accordance with manufacturer's installations instructions.  
For further assistance contact Delta Technical on 01992 523 523 or email [technical@deltamembranes.com](mailto:technical@deltamembranes.com)